

JCW-K Wireless Crane Scale

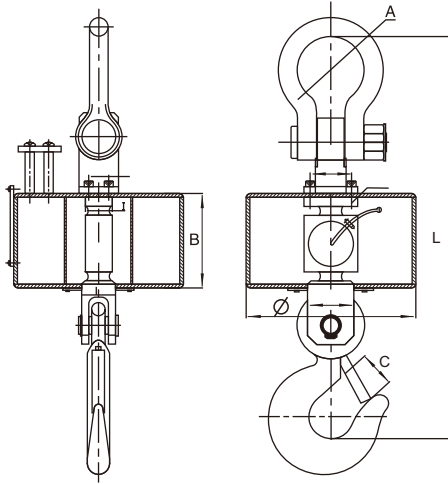

K series Scale



Type	Division	A	B	C	Ø	L	N.W.
1t	0.5kg	76	125	40	240	467	15kg
2t	1kg	76	125	40	240	467	15kg
3t	1kg	76	125	40	240	467	15kg
5t	2kg	80	125	50	240	536	23kg
10t	5kg	90	130	54	263	610	36kg
15t	5kg	135	141	60	263	729	52kg
20t	10kg	150	148	73	295	811	65kg

Features

- Newly designed K series scale, sturdy and portable
- Impact resistant all steel construction for RFI protection
- Long-life environmental LFP battery for scale

Optional Indicators



C Indicator

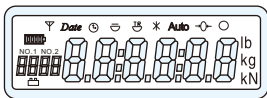

LCD Display



C II Indicator

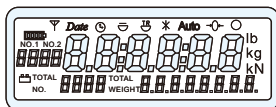

LCD Display



P II Indicator

Features

- Built-in wharf crane scale auto-weighing accumulating procedure
- Memory store up to 2900 weight data set
- Easy repair with interchangeable and compatible design
- Open procedure for adjustment and setting under different working environment
- Using RS232 interface to connect the computer
- Optional 4-20mA remote transmission module



Battery



Totalising



Wireless



Micprint

Features

- Built-in thermal microprinter
- Memory store up to 2800 weight data set
- High definition FSTN display
- With RS232, and RS485 optional
- Built-in 6V/4.5Ah LFP battery



Battery



Totalising



Wireless



Micprint

Features

- Smart hand-held wireless indicator with 32 optional frequency points
- OLED dot matrix display makes customized interface on boot-up available
- Broad range of working temperature, no delay in displaying the weighing data under low temperature
- Unique frequency sweeping function, supporting fast match and indicator mutual exchanging
- Perform as the weighing indicator or dynamometer by receiving the data transmitted from the A/D converter



Battery



Wireless



OLED Display

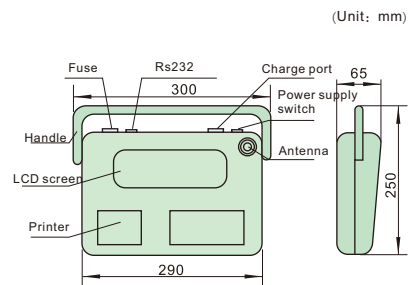

(Unit: mm)

Weighting list	
2003 /08/12 16: 00	
NO.2: 0005	
Unit: Kg	
0003	2000.0
0004	1500.0
0005	1000.0
0006	500.0

COUNT: 4	
Total:	5000.0

Print-Out Sample

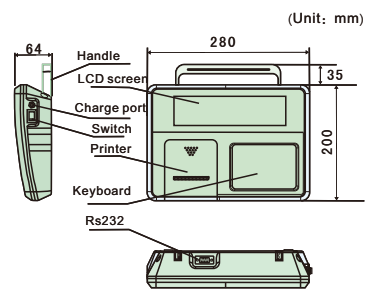

(Unit: mm)

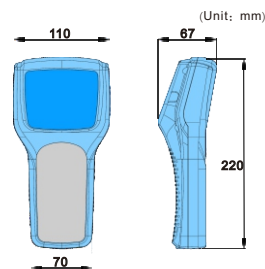

(Unit: mm)

JADEVER®



Jadever Scale Co., Ltd.
 Add: 8F, No.11 Wu-Chuan 1 Rd,
 Sinjhuang District, New Taipei
 City, Taiwan 248
 Tel : 886-2-22990203
 Fax : 886-2-22990204
 http: www.jadever.com
 E-mail:sales@jadever.com.tw

Xiamen Jadever Scale Co., Ltd.
 Add: 7F, No.40 Huli Avenue, Huli
 District, Xiamen 361006, Fujian,
 China
 Tel : 86-592-6037668
 Fax : 86-592-6037028
 http://www.jadever.com
 E-mail:xmjadever@jadever.com.cn

Jadever Weigtech, Inc.
 Add: 16 Lady Veronica Lane,
 Vaughan, Ontario L6A 0G1
 Tel: 1-905-482-2618
 Fax: 1-905-887-4066
 http://www.jadeverscale.com
 E-mail:james@jadeverscale.com